

Engineering the APX2500 Verification Methodology for Low Power

Soma Bhattacharjee,
Engineering Director
Nvidia

Nvidia APX-2500: The World's Lowest Power, High Definition Video and Graphics Computer on a Chip



- **NVIDIA® HD AVP**
 - High Definition Audio Video Processor
 - Ultra Low Power 3d graphics

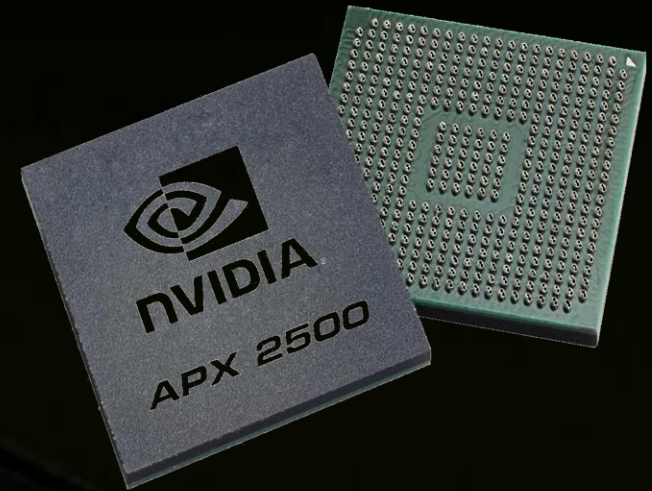

Design Challenges

- **Stringent Power Constraints**
 - Stringent power constraints at 250mW
 - Conventional power techniques no longer enough
 - Complex power management scheme requires LP design expertise and an advanced design and verification solution
- **Shrinking Time To Market**
 - Extremely tight design schedule



Attributes of a desirable verification solution



- **Power Spec and Library**
 - Concise, unambiguous and comprehensive
 - Accurate voltage aware modeling of Voltage regulators and power switches
- **Dynamic & Static Verification**
 - Low-power verification solution scaleable across projects
 - Accurate voltage aware dynamic verification
 - Comprehensive static verification with no false positives

Handicaps Of Traditional Solutions

- **Methodology**
 - Power is an after-thought
- **Flow**
 - Flow must be “enhanced” into a power-aware design flow with home-grown scripts which is a challenge to create and maintain
- **Tapeout Risk**
 - Issues too late into the design flow
 - Script guards against known mechanisms of failure – What about the “unknown – unknowns” ? – One does not want to learn this the hard way!!!

Synopsys Low-Power Verification Solution

- **MVSIM/MVRC**

- Unified infrastructure for both static and dynamic verification
- A structured silicon proven solution scalable across projects
- Automated assertions to catch errors upfront
- Solution used
 - **MVSIM** from Synopsys used for low-power dynamic verification
 - **MVRC** from Synopsys used for low-power static verification

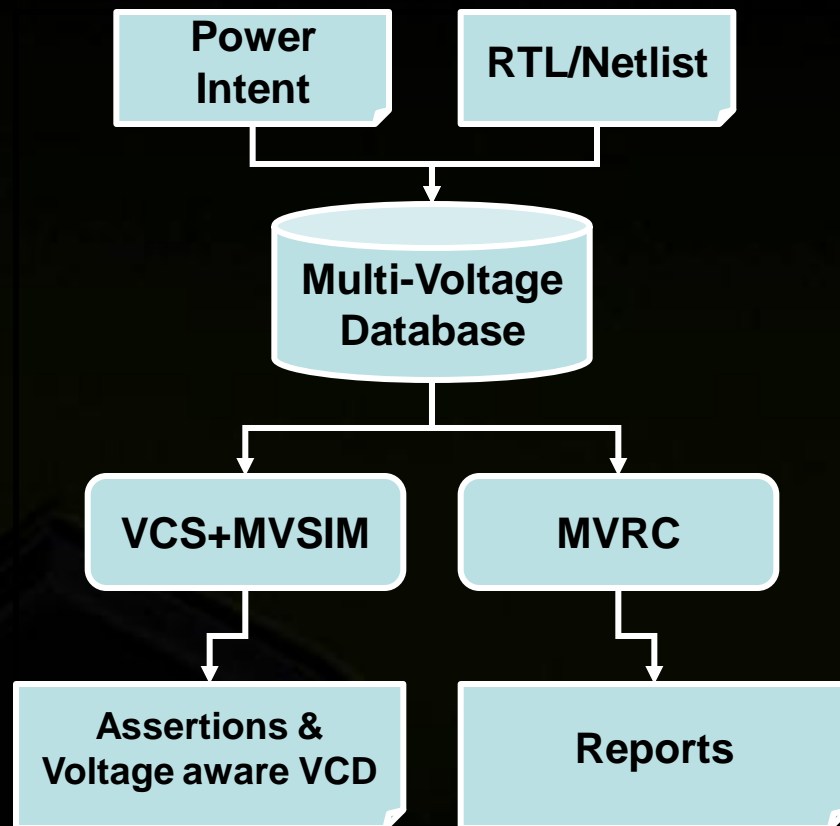

Conclusion

- MVSIM/MVRC identified design bugs missed by internal solutions, saving months of design cycle time
- MVSIM/MVRC helped in
 - Eliminating risk from the tapeout schedule
 - Identifying issues early in the design flow at RTL stage saving significant design cycle time and avoiding respins
 - Sign-off check at netlist stage ensuring silicon success
 - Establish a structured low-power verification methodology in existing design flow , scalable across projects
 - Augmented existing in-house power design flows
- First pass success of power management silicon with Synopsys' MVSIM and MVRC