

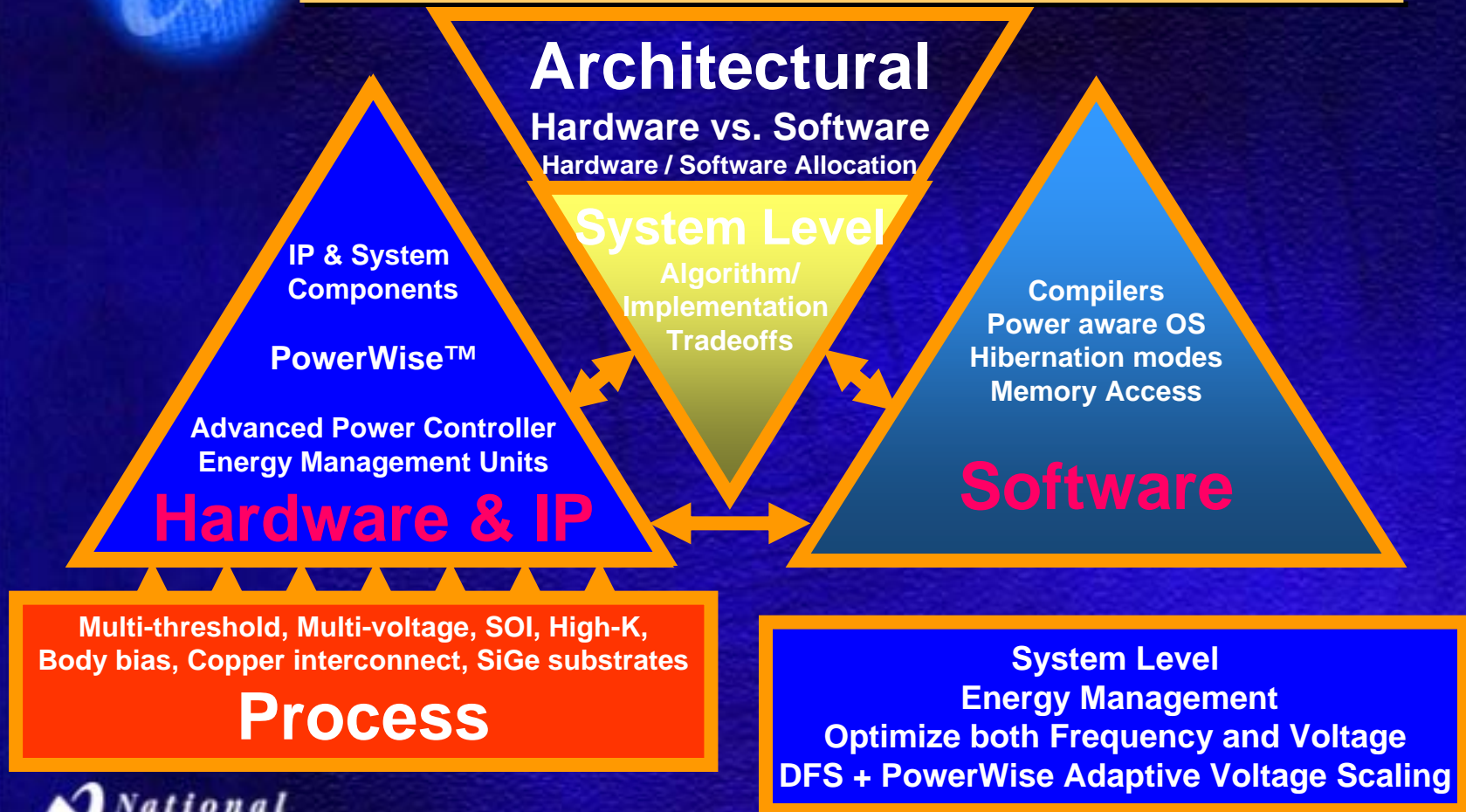

*PowerWise™ Technology*  
*Power Supply and*  
*Adaptive Voltage Control*

**Gordon Mortensen**  
**Engineering Director, Advanced Technology**  
**Portable Power Systems**

# PowerWise™ Technology



# PowerWise™ Technology

- Digital logic in scaled voltage island
- APC
  - APB peripheral
    - Control & HPM
    - Si performance compensation
      - Temperature
      - Process
  - Closed-loop AVS
  - Open-loop DVS
- EMU
  - Voltage regulator
  - Closed-loop capable

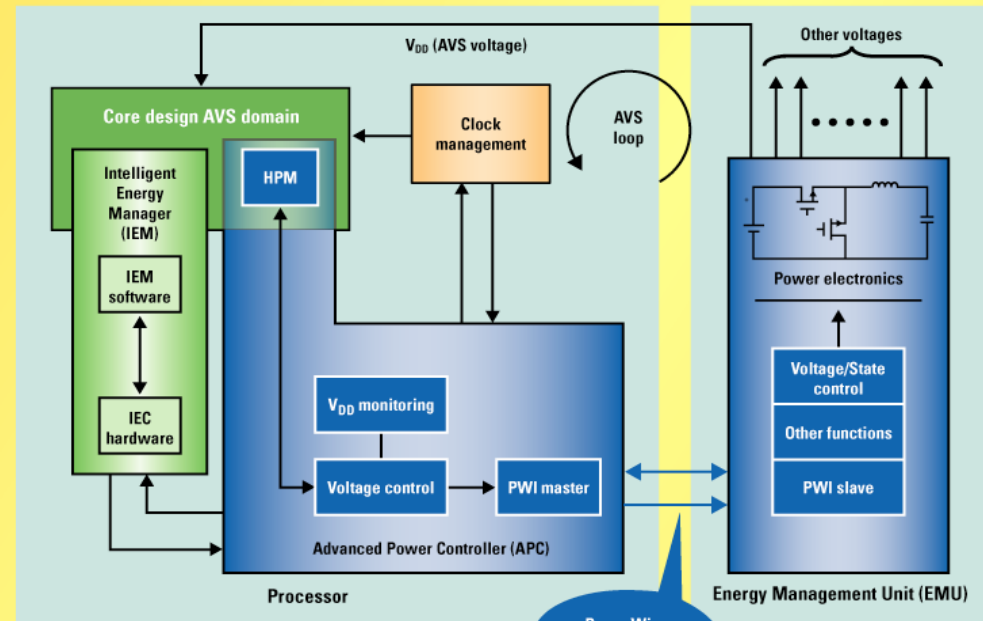

National Semiconductor's PowerWise technology (blue) works with ARM's Intelligent Energy Manager (green) to adaptively set the supply voltage and scale the clock frequency for energy efficient operation.



## *Benefits of PowerWise™ Closed-loop Approach*

---

- **Closed-loop operation provides the minimum required power supply voltage at all times**
  - Temperature compensation allows voltage to be reduced at lower temperatures
  - Process compensation allows absolute minimum voltage for any given device
- **Adaptive voltage scaling enables power reduction and energy savings in systems with**
  - Fixed frequency operation ( $V^2$  term)
  - Clock throttling without an active task manager ( $F, V^2$  terms)
  - Clock throttling with an active task manager (optimal  $F, V^2$  terms)

# Power Savings with Voltage Scaling: DVS and AVS

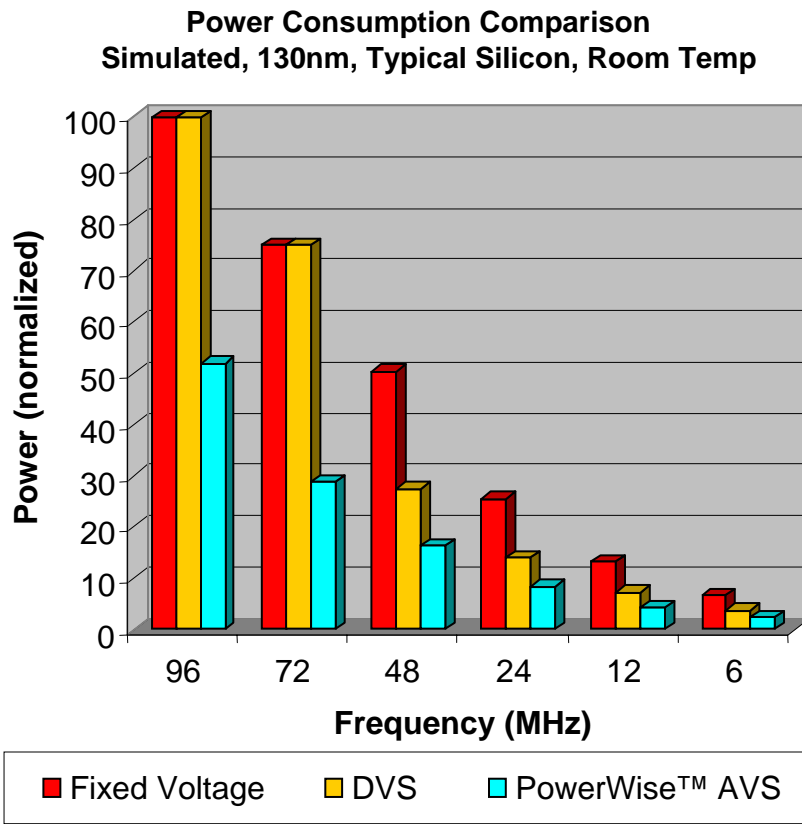

**DVS: 2 step voltage scaling**  
– 1.2V at Freq >70MHz  
– 0.9V at Freq < 70MHz

- Open-loop control of supply voltage
- No power savings at design target frequency (96MHz) over a fixed voltage system

## AVS

- Adaptive voltage for each frequency
- Closed-loop control of supply voltage
- AVS provides power savings at all operating frequencies  
– Process and temperature compensation

# Effect on Power and Energy

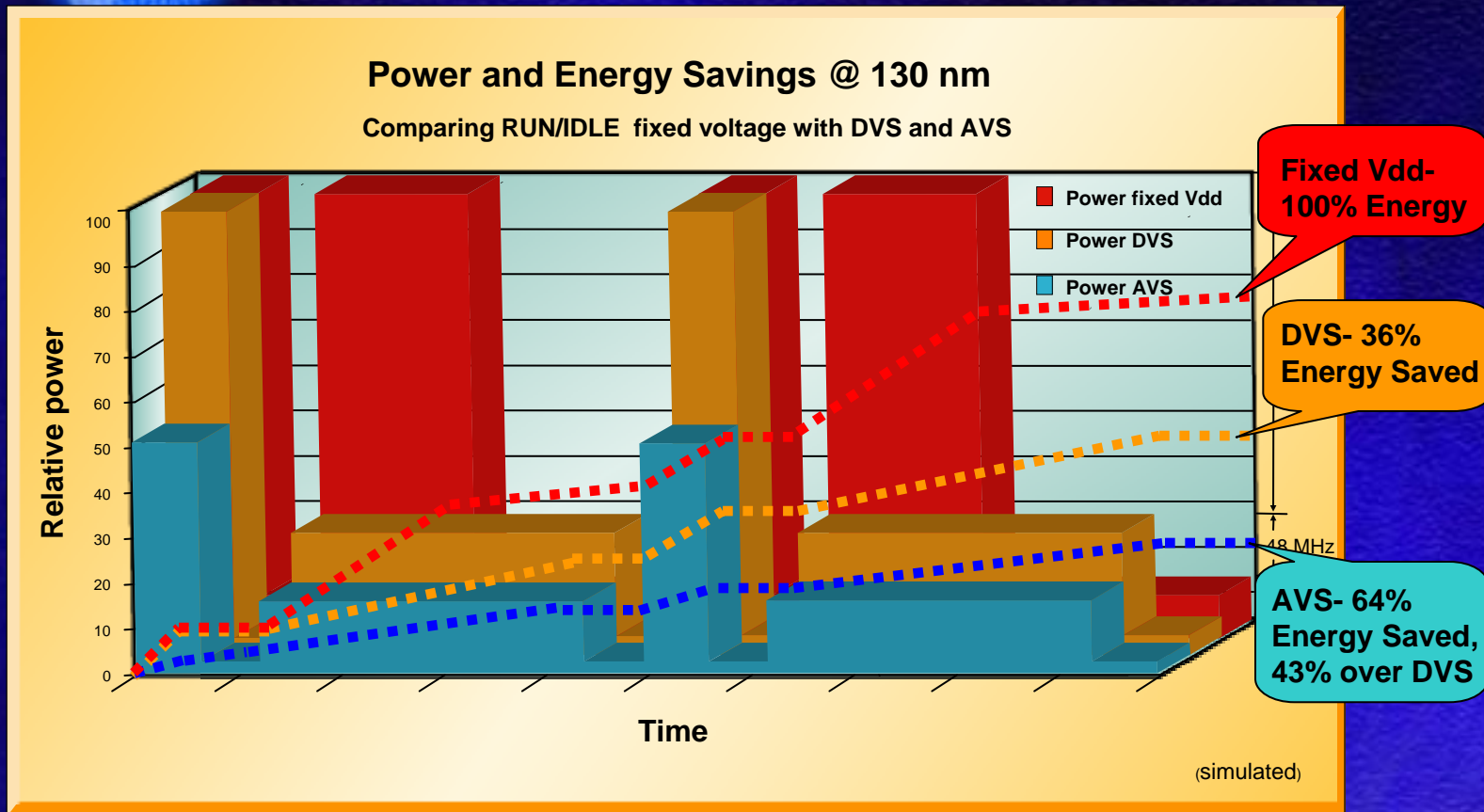

# Low Power Platform PowerWise™ Components

Provides Dynamic or Adaptive Voltage Scaling

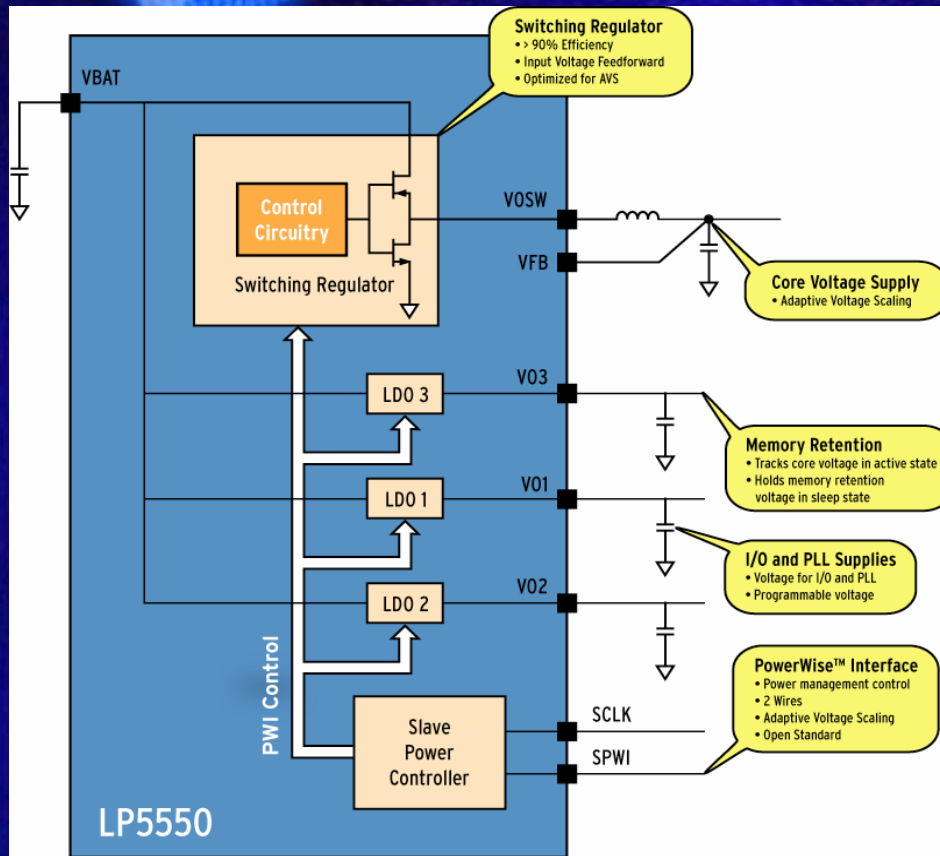

APC control logic in FPGA

EMU

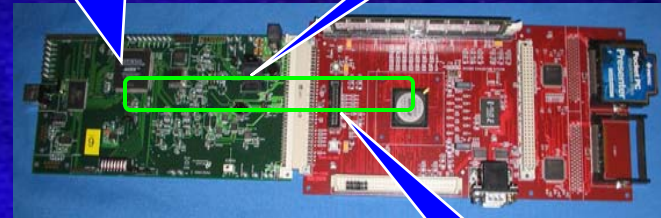

Control loop

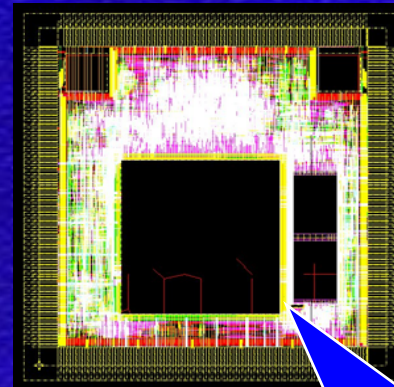

HPM on chip



# Voltage Waveforms

## DVS926 + LP5550

- MPEG4 w/IEM
- APC in closed-loop mode (AVS)

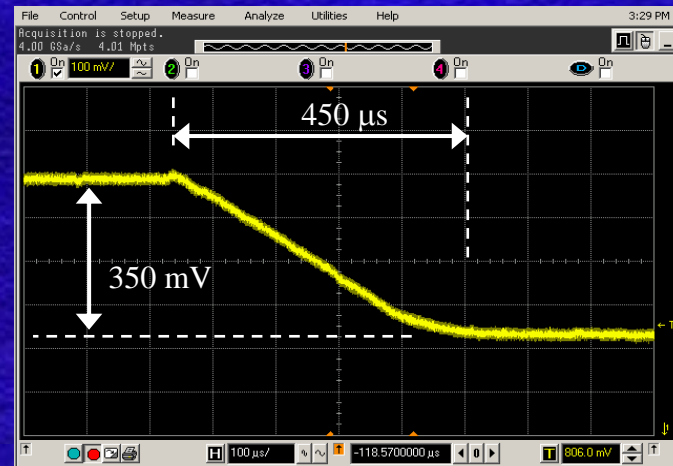
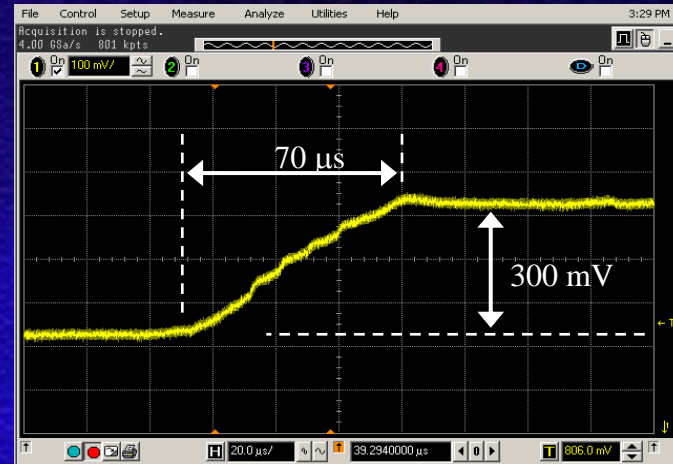
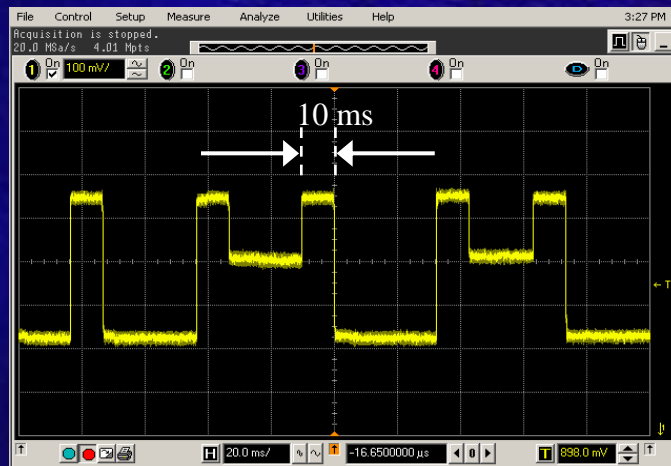



# Measured Energy Savings

- **MPEG4 w/IEM Operating frequency usage**
  - 240MHz (15%)
  - 180MHz (27%)
  - 120MHz (31%)
  - 60MHz (27%)
- **AVS using automatic voltage control (APC)**
- **DVS using estimated VDD values**

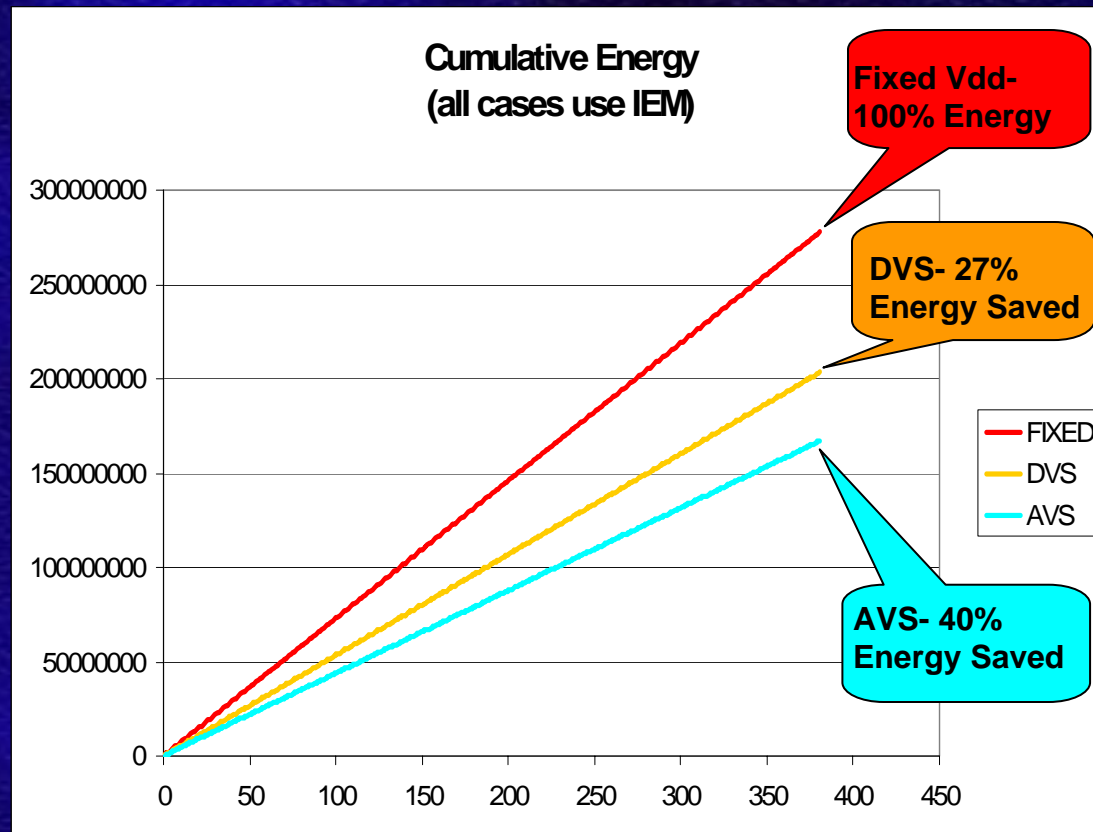

# PowerWise™ Technology Dual Domain AVS Test Chip

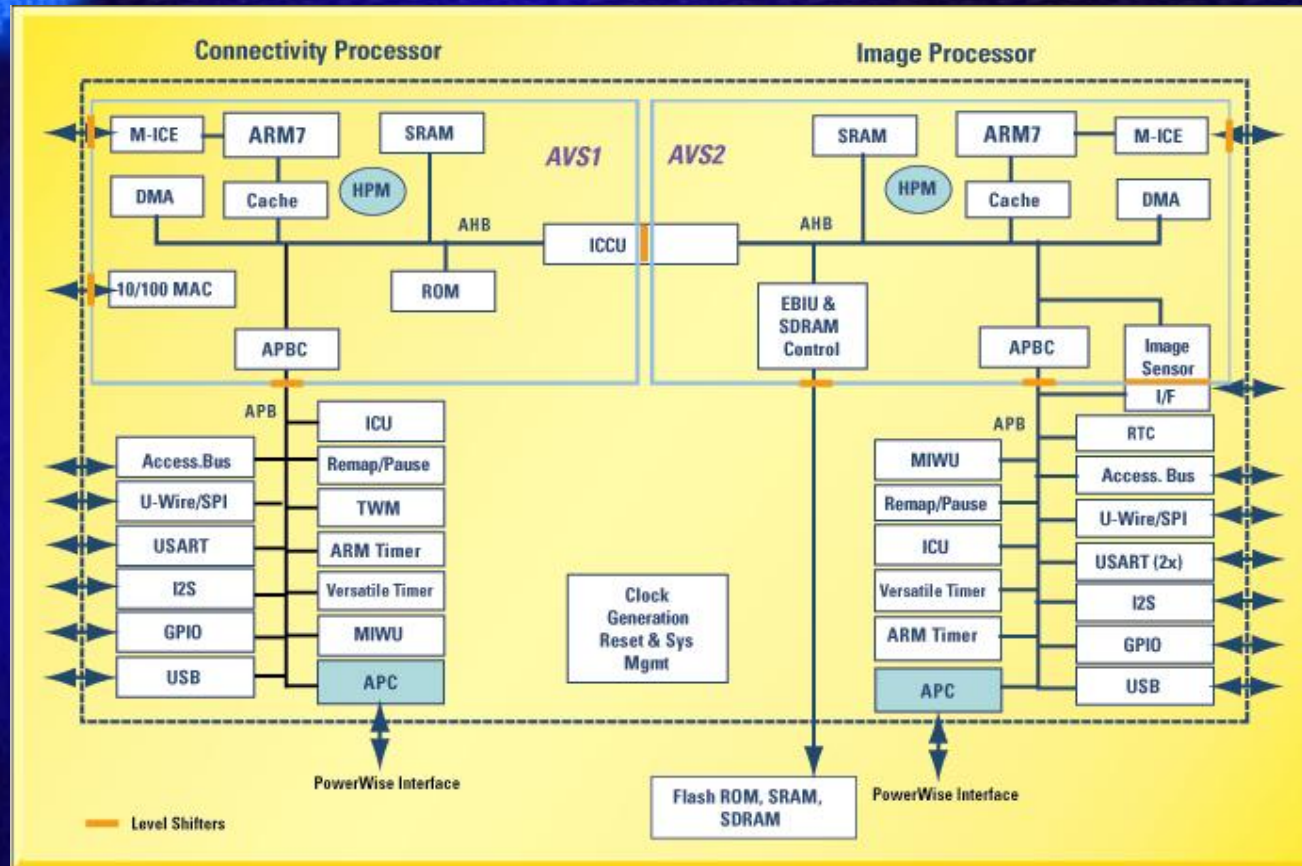

# PowerWise™ Technology Dual Domain AVS Test Chip

- **Two AVS domains**
  - AHB clusters
  - APC in fixed Vdd domain
  - HPM in scaled voltage islands
- **Memory retention, Vmem**
- **Fixed voltage domain APB clusters**
- **130nm-G TSMC process**
- **Dual ARM7 CPU cores, 96MHz design**

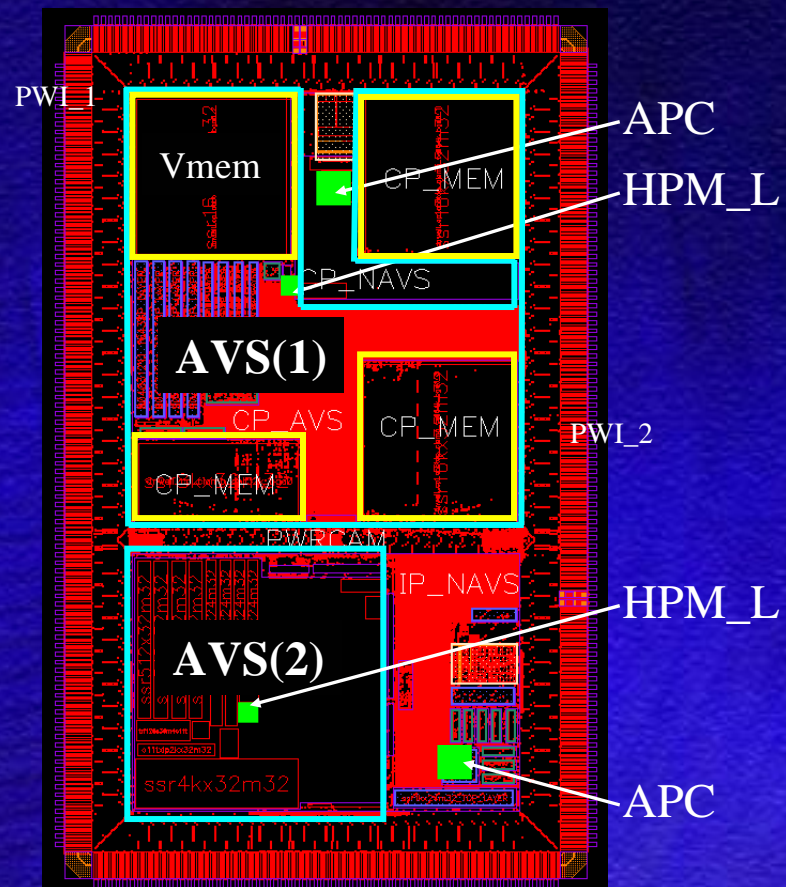



# *PowerWise™ Technology* *Low Power Components*

- **Advanced Power Controller**
  - Adaptive Voltage Scaling
    - Minimum power
    - Maximum energy efficiency
  - Integrated Hardware Performance Monitor
    - Automatic on chip process and temperature compensation
  - Power reduction possible at all frequencies
- **High Efficiency Energy Management Units**
  - Transient response correct for multi-loop control system



*National  
Semiconductor*  
The Sight & Sound of Information

October 2004

13